

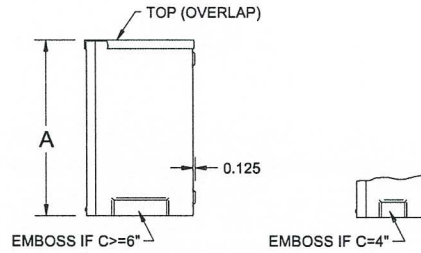

WE Series

EEMAC / NEMA 3R Weatherproof Screw Cover Boxes

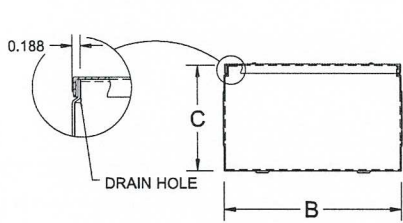

Side View

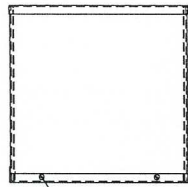

Front View

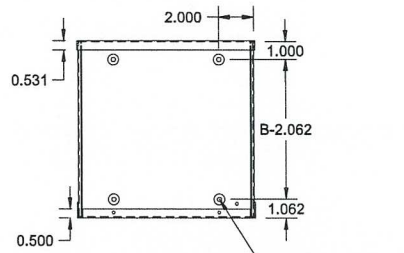

Front View
WITHOUT COVER

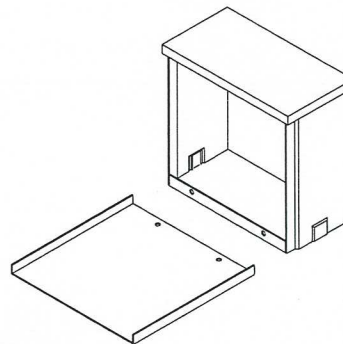

TECHNICAL READOUT

Catalog No.	Dimensions (box)			Weight lbs.
	A	B	C	
WE664	6	6	4	3
WE884	8	8	4	5
WE886	8	8	6	5.5
WE10104	10	10	4	6
WE10106	10	10	6	7
WE12124	12	12	4	7
WE12126	12	12	6	12
WE18186	18	18	6	20

Application:

Type 3R weatherproof enclosure generally used as a junction or pull box.

Construction:

- 16, gauge steel
- Mounting holes on back for vertical installation only
- No gasketing, drip shield top
- 2 x drain holes
- ANSI / ASA 61 grey polyester textured powder coating inside out

Standards:

- UL listed E205524

